Sys*Stim[®] 226

Instruction Manual



1333 South Claudina Street
Anaheim, CA 92805, U. S. A.

Toll Free: (800) 854-9305

Telephone: (714) 533-2221 • FAX: (714) 635-7539

Web site: www.mettlerelectronics.com • email: mail@mettlerelectronics.com

Table of Contents

Section	Title	Page
1	Introduction	5
1.1	Introduction to the Sys*Stim 226	5
1.2	Introduction to this Manual	6
1.3	Safety Precautions	6
1.4	Caution	6
1.5	Shipping Damage	6
1.6	Package Contents	7
1.7	Limited Warranty	7
2	Symbol Glossary and List of Abbreviations	9
2.1	Symbol Glossary	9
2.2	List of Abbreviations	11
3	Installation	13
3.1	Installation Instructions	13
4	Operating Instructions	15
4.1	A Note About Electrodes	16
4.2	Operating Instructions	17
4.3	Electrode Positioning	22
4.4	Combination Therapy Using the Sys*Stim 226 and the Sonicator	25
5	Indications, Contraindications, Precautions and Adverse Reactions	27
5.1	Indications	27
5.2	Contraindications	27
5.3	Warnings	28
5.4	Precautions	28
5.5	Side Effects/ Adverse Reactions	29
6	Maintenance and Troubleshooting	31
6.1	Cleaning the Sys*Stim 226	31
6.2	Routine Maintenance	31
6.3	Troubleshooting the Sys*Stim 226	31
7	References	33
8	Specifications	35
8.1	General Specifications	35
8.2	Waveform Specifications	35
8.3	Amplitude Modulation Specifications	38
9	Accessories	39
9.1	Ordering Information	39
9.2	Sys*Stim 226 Accessories	39

List of Figures

No.	Title	Page
1.1	Sys*Stim 226 and Accessories	5
3.1	Sys*Stim 226, Bottom view – Mains Power Switch and Line cord connections	13
4.1	Front membrane panel and LED indicators	15
4.2	Electrode Sizes and Current Density	16
4.3	Quadpolar Electrode Placement Technique	23
4.4	Bipolar Electrode Placement Technique	23
4.5	Monopolar Electrode Placement Technique	24
4.6	Using the Pencil Electrode	24
4.7	Combination Therapy	26
4.8	Application of Combination Therapy	26
8.1	Interferential Waveform	35
8.2	Premodulated Waveform	36
8.3	Medium Frequency (<i>Russian</i>) Waveform	37
8.4	Biphasic Waveform	37

Section 1: Introduction

1.1 Introduction to the Sys*Stim 226

Thank you for purchasing the Sys*Stim 226 neuromuscular stimulator from Mettler Electronics Corp. The microprocessor controlled Sys*Stim 226 provides interferential, premodulated, medium frequency and symmetrical biphasic waveforms with enhanced reliability and ease of use.

The two-channel Sys*Stim 226 allows you to utilize two different waveforms using two different treatment timers simultaneously. You can choose between several different amplitude modulation options such as the surge, reciprocation and amplitude modulation (*interferential only, vector rotation*). The interferential and premodulated modes offer frequency modulation as well as a fixed frequency.

The membrane panel provides one touch entry for treatment parameters. An audible tone provides you with further reinforcement that you have made a selection. LED's guide you through the easy setup routine.

Use the lightweight and portable Sys*Stim 226 in home health as well as in the clinic. Teamed up with a Mettler Electronics Sonicator, the Sys*Stim 226 can provide combination therapy. Add the optional treatment cart along with a Sonicator® therapeutic ultrasound to create a mobile treatment center in your office.



Figure 1.1 – Sys*Stim 226 and Accessories

1.2 Introduction to This Manual

Read the contents of this manual before treating patients with the Sys*Stim 226.

This manual has been written to assist you with the safe operation of the Sys*Stim 226. It is intended for use by the owners and operators of the Sys*Stim 226. The goal of this manual is to direct the correct operation and maintenance of this unit.

The specifications and instructions presented in this manual are in effect at the time of its publication. These instructions may be updated at any time at the discretion of the manufacturer.

1.3 Safety Precautions

The Sys*Stim 226 operates with high voltages. Servicing of the Sys*Stim 226 should be performed by qualified biomedical technicians with experience in neuromuscular stimulator service or it should be returned directly to the factory. To maximize safety during use, the unit should be plugged into a grounded wall outlet of proper voltage only. General safety guidelines for medical electronic equipment should be followed.

A maintenance manual for the Sys*Stim 226 is available from Mettler Electronics Corp. for a small fee. For more information, contact Customer Service by calling toll free at (800) 854-9305, *telephone: (714) 533-2221*, Fax: (714) 635-7539 or via email, *mail@mettlerelectronics.com*.

1.4 Caution

Federal law restricts the sale of this device to, or on the order of a physician, dentist, veterinarian or any other practitioner licensed by the law of the state in which he practices.

Use of controls or adjustments or performance of procedures other than those specified herein or use of unauthorized accessories with this device may result in exposure to hazardous electrical current and possible burns caused by abnormal current levels.

The electric energy delivered by this device may possibly be lethal. Treatment should be administered only under the direct supervision of a health care professional.

1.5 Shipping Damage

Your new Sys*Stim 226 is shipped complete in one carton. Upon receipt, please inspect the carton and the unit for visible and hidden damage. If you discover any damage, hold all shipping materials, including the carton, and call the shipping agent who delivered the unit.

The carton in which your new Sys*Stim 226 was received is specially designed to protect the unit during shipping. Please retain all shipping materials in the event that you will need to return your unit for servicing. NOTE: All warranty repairs are to be performed by Mettler Electronics Corp. or an authorized Mettler Electronics warranty repair center.

1.6 Package Contents

Your new Sys*Stim 226 comes complete with all the necessary components to perform neuromuscular electrical stimulation. Below is a list of items that are included in the shipping carton.

1. Sys*Stim 226
2. Two electrode cable sets, (ME 2260)
3. Two gray pin to banana adapters, (ME 2027)
4. One package each EZ Trodes, 2" diameter (ME 2221) and 3" diameter (ME 2222)
5. Detachable U.L. listed, hospital-grade line cord, (ME 7293)
6. Instruction Manual and Warranty Card

1.7 Limited Warranty

The Sys*Stim 226 neuromuscular electrical stimulator is warranted against defects in materials and workmanship for a period of two years from date of purchase. During the applicable warranty period Mettler Electronics Corp. will, at its discretion, either repair or replace the Product without charge for these types of defects.

For service under this warranty, the Product must be returned by the buyer within the applicable warranty period to Mettler Electronics Corp. **Shipping charges to Mettler Electronics Corp. under this warranty must be paid by the buyer. The buyer must also include a copy of the sales receipt or other proof of the date of purchase. If the Product is returned without proof of the date of purchase, it will be serviced as an out-of-warranty product at Mettler Electronics Corp.'s prevailing service rates.**

Alteration, misuse, or neglect of the Product voids this warranty. Except as specifically set forth above, Mettler Electronics Corp. makes no warranties, express or implied, including without limitation any implied warranty of merchantability or fitness for a particular purpose, with respect to the Product. If any implied warranties apply as a matter of law, they are limited in duration to one year.

Mettler Electronics Corp. shall not be liable for any indirect, special, consequential or incidental damages resulting from any defect in or use of the Product.

Any legal action brought by the buyer relating to this warranty must be commenced within one year from the date any claim arises and must be brought only in the state or federal courts located in Orange County, California.

Some states do not allow limitations on how long an implied warranty lasts, or the exclusion or limitation of incidental or consequential damages, so the above limitations or exclusions may not apply to the buyer. This warranty gives the buyer specific legal rights, and the buyer may also have other rights which vary from state to state.

Section 2—Symbol Glossary and List of Abbreviations

2.1 Symbol Glossary



Time display



Channel timer indicator LED's. Example: Indicator LED for channel 1 will be lit when the time displayed is for channel 1 in the 2-timer mode. Both indicators will be lit when the time displayed applies to both channels. Channel 1 or 2 LED will blink to indicate "adjust intensity for the selected channel" in the reciprocation and surge modes.



These LED's will illuminate to prompt the clinician to input either time in seconds or microseconds or frequency in Hz. The time or the frequency will be displayed in the numeric time display.

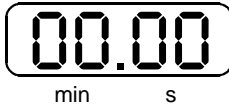

Time display LED's. Displays treatment time and numeric values for frequency, phase duration and on/off times.



Numeric keypad for time, frequency or phase duration entry.



Starts treatment, stimulation output activated.



Stops treatment in the channel displayed in timer window or acts as an "Enter" button during treatment setup.



Stops all stimulation output from both channels.



Interferential waveform selector – LED is illuminated when this function is activated.



Premodulated waveform selector – LED is illuminated when this function is activated.

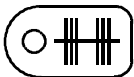

Medium frequency waveform selector – LED is illuminated when this function is activated.

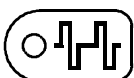

Symmetrical biphasic waveform selector – LED is illuminated when this function is activated.



Phase duration control selector – Press this button during a biphasic treatment to display phase duration.

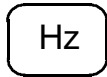

Frequency control selector – Press this button during a biphasic treatment to display frequency.

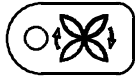

Amplitude modulation, used for interferential waveform only. LED is illuminated when this function is activated.

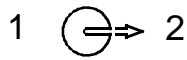

Stimulation output being displayed

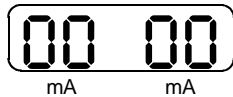

LED's that display the output intensity during a treatment. When the unit is in the "Hold" mode, "-- --" will be displayed.

Stimulation output intensity controls – intensity may be adjusted at any time with the continuous mode for all waveforms. It may be adjusted up or down during the "On" phase of the surge and recip modes. And it may be adjusted down at any time when vector rotation is active in the interferential mode.

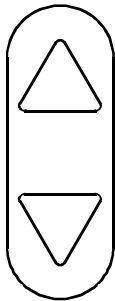

- Increase output intensity
- Decrease output intensity

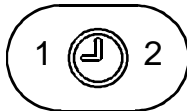

Switches timer display and programming control from channel 1 to channel 2 or vice versa when the two timer option is selected (LED on).



Continuous stimulation, no amplitude modulation selector – LED is illuminated when this function is activated.

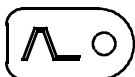

Amplitude modulation (surge) selector – Press this button during a treatment to display surge "on / off" times. LED is illuminated when this function is activated.

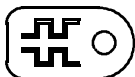

Reciprocation selector (two channels only) – Press this button during a treatment to display reciprocation "on / off" times. LED is illuminated when this function is activated.

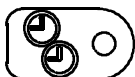

Use two timers. Allows clinician to program two different treatment protocols under the control of two different timers. LED is illuminated when this function is activated.

|

Mains On.

O

Mains Off.



Refer to instruction manual for directions.

2.2 List of Abbreviations

cm ²	–	square centimeters
Hz	–	Hertz (pulses per second)
LED	–	Light Emitting Diode
mA	–	milliampere (1/1000 ampere)
min	–	minutes
ms	–	millisecond (1/1000 second)
s	–	seconds
S/N	–	Serial Number
μs	–	microsecond (1/1,000,000 second)

Section 3—Installation

3.1 Installation Instructions

1. Connect the line cord to the bottom of the Sys*Stim 226. (See Figure 3.1)
2. Plug the line cord into a grounded wall outlet that has 115 VAC, 50/60 Hz. Your power supply must match the voltage requirements listed on the serial number label of your device. **Do not connect the Sys*Stim 226 to a power supply rated differently than that described above.**
3. The line cord comes equipped with a standard 3-prong plug. This plug provides grounding for the Sys*Stim 226. Do not defeat its purpose by using 3-to-2 prong adapters or any other means of attaching to a wall outlet.
4. The Sys*Stim 226 may be susceptible to interference originating from shortwave diathermy units operating in close proximity to it. Avoid operating the Sys*Stim 226 adjacent to and simultaneously with operating shortwave devices.
5. **Do not use sharp objects to operate the membrane panel switches.** If the tough outer layer of the membrane is broken, moisture may leak into the switches resulting in switch failure.

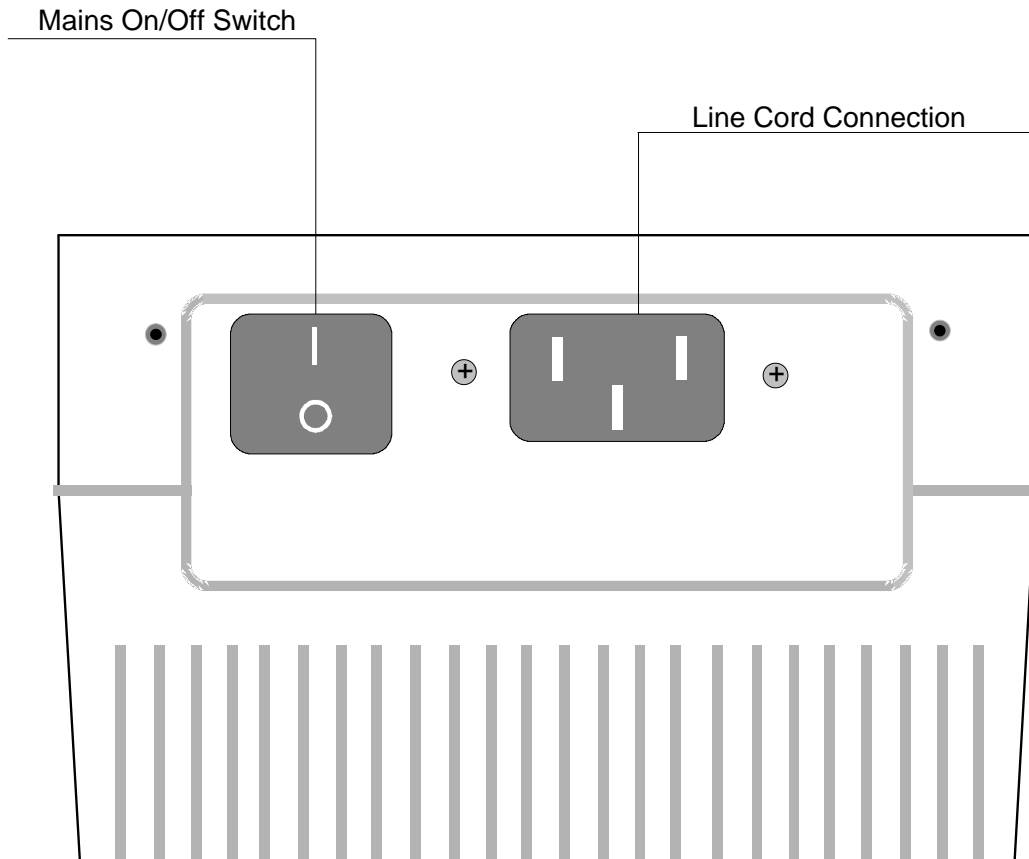

Figure 3.1 – Sys*Stim 226, Bottom view – Mains Power Switch and Line cord connection

Section 4—Operating Instructions

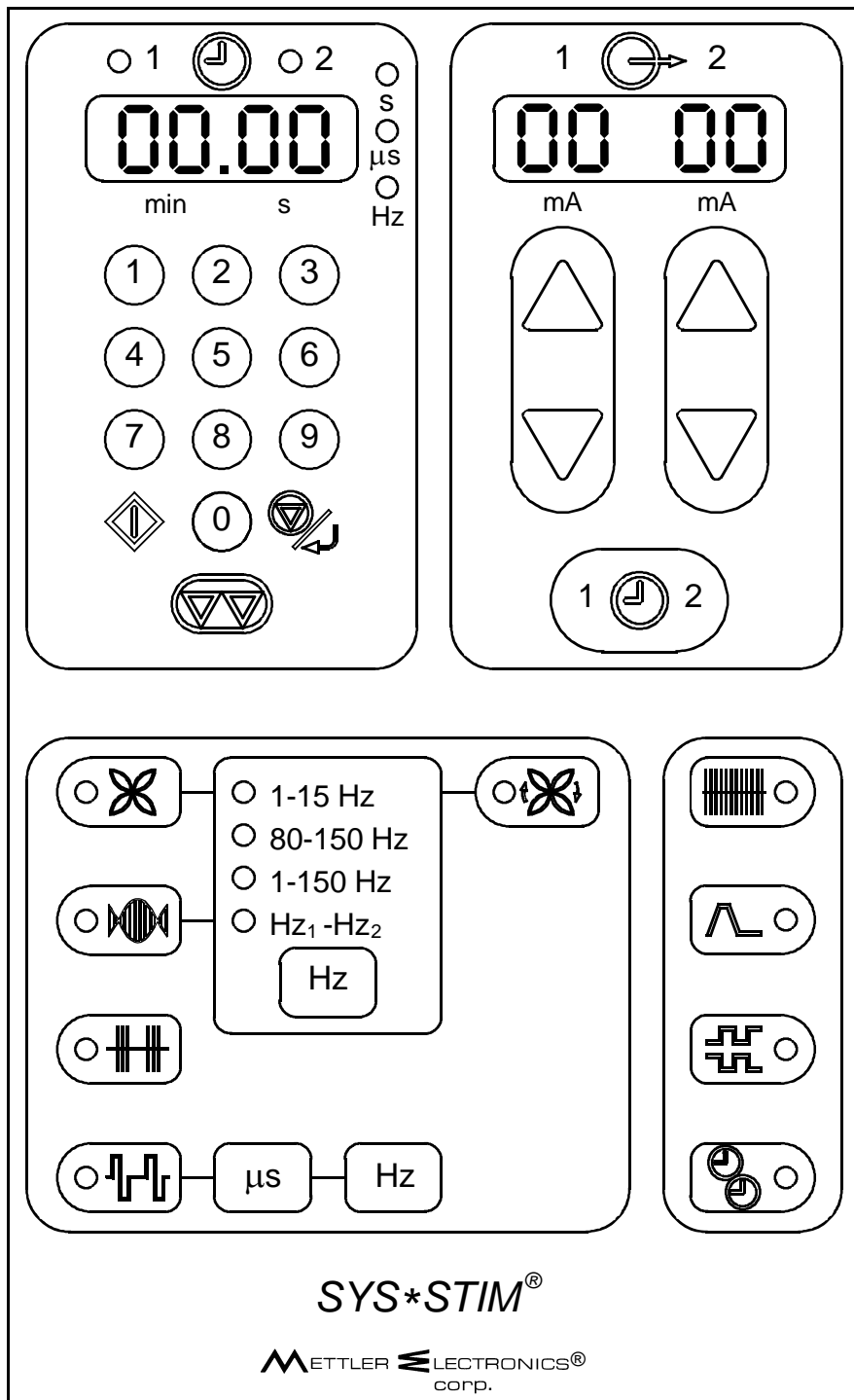

Figure 4.1 – Front membrane panel and LED indicators

4.1 A Note About Electrodes

To ensure safe operation of the Sys*Stim 226, follow the recommendations listed below:

1. We strongly encourage careful maintenance of the electrode system. This includes the lead wires as well as the pads themselves. Worn cables and/or poor pads (or the wrong sized pads) can have a significant impact upon treatment results.
2. Do not exceed the number of recommended uses listed on the instructions for EZ Trodes or other reusable self-adhesive electrodes.
3. Make sure that the entire surface of the electrode is contacting the patient.
4. Do not use moist hot packs to secure electrodes.
5. To avoid skin irritation due to high current density, do not use electrodes smaller in surface area than the 2" in diameter EZ Trode[®] self-adhesive electrode (ME 2221).
6. Do not use conductive carbon electrodes with this product.
7. Whenever clinically possible, utilize the largest possible pads to reduce local increases in current density. In situations where small pads are required, use the lowest stimulation intensity necessary to achieve the desired clinical results.

The table below illustrates the relationship between electrode diameter and current density. As you can see the current density increases rapidly when diameter decreases.

Diameter <i>inches</i>	Surface Area <i>Square inches</i>	Current Density <i>mA/sq in (for 10mA)</i>
1.25	1.2	8.2
2.00	3.1	3.2
3.00	7.1	1.4

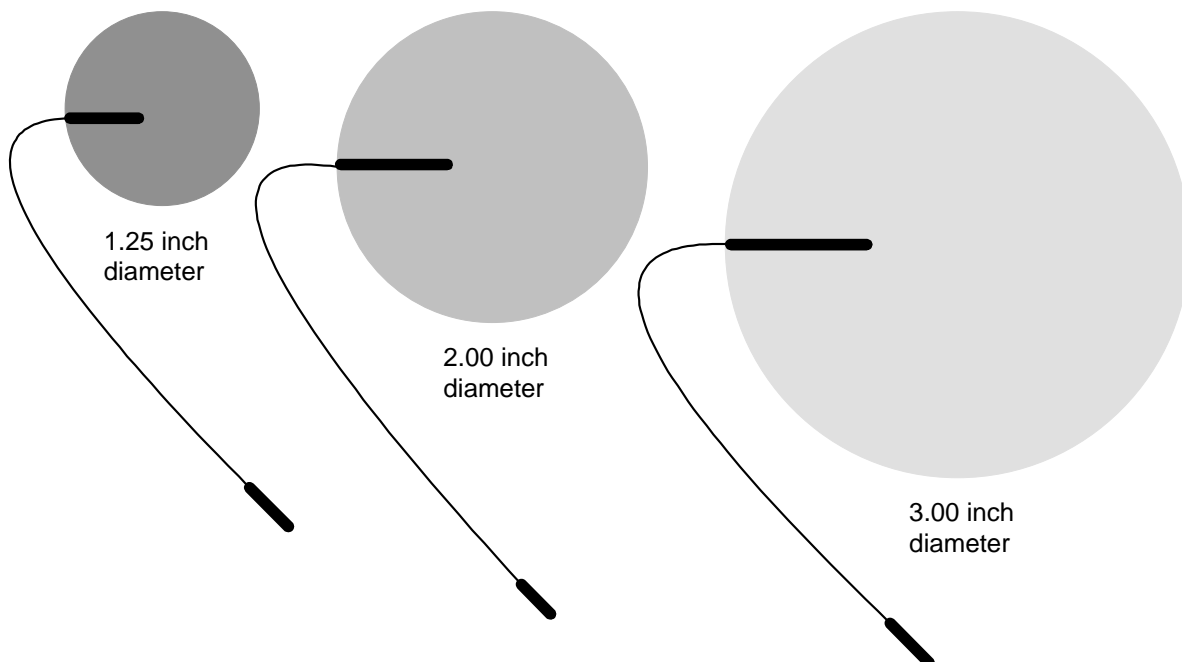
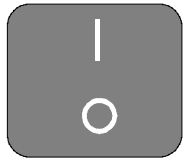

Figure 4.2 – Electrode Sizes and Current Density

4.2 General Operating Instructions:

Before you start:

- a) Review precautions, contraindications and side effects/adverse reactions listed in Section 5.
- b) Use Mettler Electronics electrodes to ensure safe and effective operation.
- c) Verify connection of the line cord to a grounded wall receptacle and the Sys*Stim 226.
- d) Note: Descriptions of the symbols used on controls are in Section 2.



1. Turn on the mains power switch by pressing “I” icon on switch.

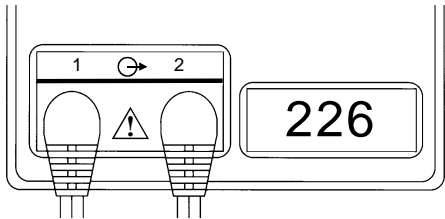

2. Insert the connectors attached to the electrode cables (ME 2260) into the electrode cable receptacles illustrated on the left.

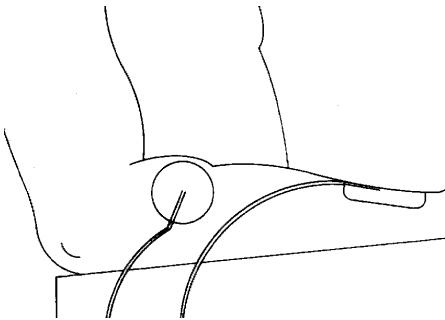

3. Attach electrodes to electrode cables. Apply the electrodes to the patient after reviewing “A Note about Electrodes”.

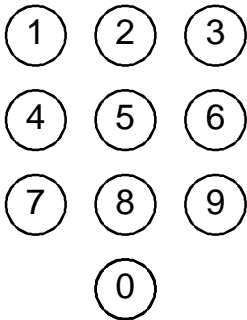

4. Select the desired treatment time by pressing a number(s) on the numeric keypad. Unit beeps when a button is pressed. Only whole minutes may be selected. Treatment times from 1 to 60 minutes are valid. Time is displayed in the time window. During a treatment time remaining is displayed in minutes and seconds.

To treat without a set time, do not enter a time value. The timer will count up to indicate time elapsed since the beginning of the session.

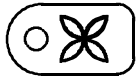

• Interferential



• Premodulated
(Bipolar)

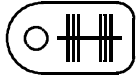

• Medium
Frequency
(Russian)



• Biphasic

5. Select the waveform for this treatment session. The default waveform is the interferential waveform.

6. Set treatment phase duration (*biphasic only*) and frequency. Please note: *Medium frequency has a fixed phase duration and frequency so no adjustments are necessary.*

1-15 Hz
 80-150 Hz
 1-150 Hz
 Hz₁ -Hz₂

• Interferential
• Premodulated
(Bipolar)



Hz

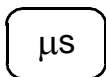

• Biphasic



μs

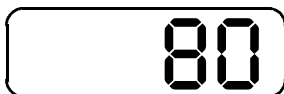
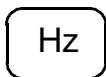

Hz

• Select frequency modulation for *the Interferential or Premodulated* modes by pressing the button labeled “Hz” until the LED to the left of the desired selection is illuminated. For “Hz₁-Hz₂” input any value from 0–250 for Interferential mode or 1–250 for Premodulated mode using the numeric key pad and then press . Repeat the same procedure for the second frequency in the range. For a fixed treatment frequency, input the same value twice.

• Select phase duration in μs. Enter any value from 50–300 μs using the numeric key pad and then press . The Sys*Stim 226 stores the value of the last phase duration used and displays it in the timer window. If the displayed value is the one you want either press or the button labeled “μs”.

• Select frequency in Hz. Enter any value from 1–120 Hz using the numeric keypad and then press . The Sys*Stim 226 stores the value of the last frequency used and displays it in the timer window. If the displayed value is the one you want either press or the button labeled “Hz”.

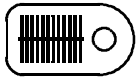

- Continuous



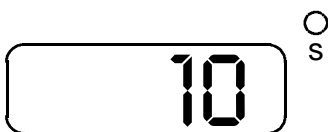

- Surge



7. Select the amplitude modulation method for this treatment session for the Premodulated, Medium Frequency and Biphasic modes only. The default is continuous.

⇒ **Surge Mode**

- Press the “Surge” button to select on and off times. The up and down ramps are fixed to 3 seconds up and 2 seconds down. The preset on/off times (*in seconds*) are: 10 on/10 off, 10 on/20 off, 10 on/30 off, 10 on/40 off, 10 on/50 off and 10 on/60 off. On/Off times are displayed in the timer window.
- Continue pressing the “Surge” button until the desired on/off time is displayed in the timer window. Then Press  to enter that on/off time.
- To select a custom on/off time, press the “Surge” button one more time after “10 60” is displayed. A single number is displayed in the timer window. This is the on time. Use the numeric keypad to select an on time in seconds from 1 to 240. Press  to enter the on time. A second single number is displayed in the timer window. This is the off time. Use the numeric keypad to select an off time in seconds from 1 to 240. Press  to enter the off time.
- To review an on/off time during a treatment, press the “Surge” button. Surge on/off time will be displayed briefly in the timer window.

⇒ **Reciprocation Mode**

- Press the “Reciprocation” button to select reciprocation times between channels one and two. The up and down ramps are fixed at 1 second. A single number is displayed in the timer window. Use the numeric keypad to select a reciprocation time in seconds from 2 to 240. Press  to enter the reciprocation time. Each channel will be on and off for the time set in a reciprocal fashion.
- To review an on/off time during a treatment, press the “Reciprocation” button. Reciprocation time will be displayed briefly in the timer window.
- For reciprocation with unequal on and off times first press the reciprocation button and

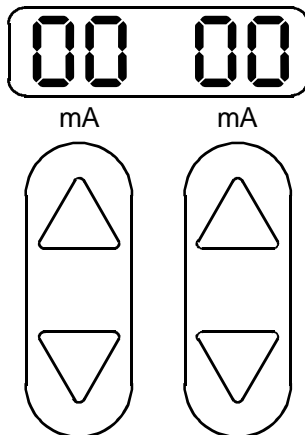
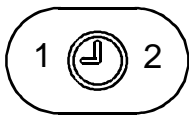
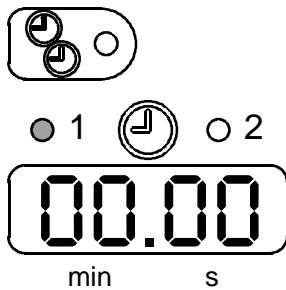

then press . Press the surge button and then follow the instructions to set on/off times in the surge mode. First channel one will be on for the set on time and then channel two will come on during the set off time.

- To review an on/off time during a treatment, press the “Reciprocation” button. Reciprocation time will be displayed briefly in the timer window.

8. Use the two timer option to use two different treatment protocols or two different treatment times simultaneously. Individual treatments can be setup, started and stopped independently. This option is available with the premodulated, medium frequency and biphasic modes. Use the two timer mode with the “Continuous” and “Surge” amplitude modulation options. The indicator LED will be lit for the channel that is being displayed at any one time. Program the single channel just like you would program the Sys*Stim 226 for two-channel operation.



- To switch between the two channels either during setup or during a treatment press the button shown at the left. The time and the treatment protocol are displayed for the channel whose indicator LED is lit.

9. Press  after all treatment parameters have been set to begin treatment.

10. “-- --” is displayed in the mA display followed by double zeroes indicating that the channels are active. *In the two timer mode of operation, the active channels will display 00's. If either channel is off its display will show “--”.* Press the “Up” or “Down” arrows to adjust treatment intensity. The numbers in the display will increase as the “Up” arrow is depressed. If you press an arrow one time the intensity will increase or decrease in small increments. If you hold an arrow down, the Sys*Stim 226 will beep three times and then the intensity will increase rapidly until the button is released.

- In the “Surge” mode, the Sys*Stim 226 allows you to adjust the treatment intensity before beginning the “On/Off” cycle that you selected. The green LED’s above the time window will blink on and off to alert you to adjust treatment intensity. Use the “Up” or “Down” arrows for both channels to

adjust intensity to the desired level. Then press  again to initiate the treatment cycle. The intensity may be adjusted only during the “On” part of the “Surge” cycle.

- In the “Reciprocation” mode, The Sys*Stim 226 will prompt you to adjust the intensity in Channel 1. Once you have made the adjustment press . You will then be prompted to adjust the intensity in Channel 2 by the flashing LED for that channel. Adjust the intensity and then press . The mA in Channel 2 will ramp down and the reciprocation mode will begin cycling with Channel 1 active first. Again, the output intensity in mA is displayed in the output window.
- In the “two timer” mode the LED above the channel that is active will be on or blinking to guide you through adjusting the treatment intensity.



11. In the “Interferential” mode you may choose to activate the vector control button after the intensities for both channels have been set to patient comfort. *It is not recommended that you adjust the intensity level to **tolerance**, since the field moves within the tissues and some areas may be more sensitive than others..* You will also notice that the intensity level of one channel increases by 50% while the intensity level of the other channel decreases by 50%. The intensity of the combined channels however, remains constant.

After you engage the vector control button, you can adjust the treatment intensity *down* at any time. You can adjust the intensity up, only at the peak for that channel. By adjusting the intensity in either channel, you can change the interferential field to target the area being treated.



“Single” Hold



“Double” Hold

12. Press either of these two buttons to hold treatment at any time and stop all output to the patient. Time remaining or time elapsed will display in the timer window. “-- --” will display in the output window.

- In the single timer mode, both buttons will stop treatment in both channels.
- In the “Two timer” mode, pressing the upper button stops treatment only for the channel indicated by the illuminated green LED above the time window.

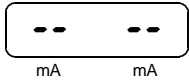
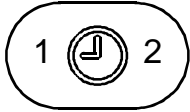

- In the “Two Timer” mode, pressing the lower button stops treatment in both channels.

13. In the “Two Timer” mode, use this button to either program or view the time remaining for the other channel. The output display remains active for both channels regardless of which channel is selected by this control.

14. At the end of treatment, the Sys*Stim 226 will beep three long beeps to indicate the end of treatment. The output to the patient will stop. The timer display will show “00.00” and the mA display will show “---”.

4.3 Electrode Positioning

1. General information

Placement of electrodes may be by the quadpolar, bipolar or monopolar techniques. Proper positioning and contact will insure treatment comfort and efficiency. Electrodes should never be placed in such a manner as to produce current flow through the cardiac area. For safe operation of the Sys*Stim 226, review contraindications, warnings, precautions and Side Effects/ Adverse Reactions in sections 5.2, 5.3, 5.4 and 5.5 before positioning electrodes.

2. Preparation of the skin prior to electrode application

To insure the efficient current conduction necessary for proper treatment, certain preparations must be made. Cleaning or wetting should eliminate any impairment to current conduction on the patient’s skin such as an oily or dry surface, or excessive hair coverage. Shaving may be necessary depending upon the density of hair coverage. **Failure to provide for maximum current conduction efficiency could result in skin irritation relating to an increase in current density at the electrode site.**

Using reusable electrodes for longer periods of time than those recommended by the package insert could result in ineffective treatments or cause skin irritation. Care should be taken to ensure application of the total electrode surface area to the patient's skin prior to commencing treatment.

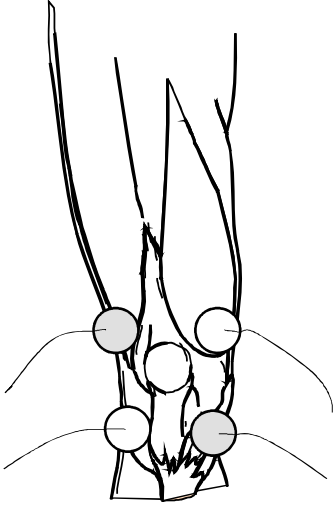

Figure 4.3 – Quadpolar Electrode Placement Technique

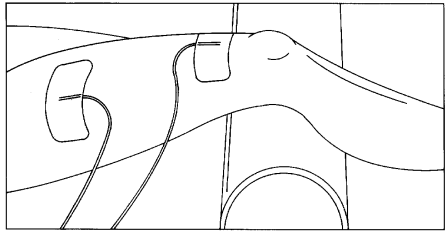

Figure 4.4 – Bipolar Electrode Placement Technique

3. Quadpolar electrode application technique

Quadpolar techniques should be used with the “Interferential” waveform. The electrodes from Channel 1 are placed diagonally from each other. While the electrodes from Channel 2 are placed diagonally across from each other to form an “X” over the treatment area. The zone of maximum interference between the two channels occurs roughly in the center of the “X”.

Adjusting the intensity levels of the two channels will change the apparent interference pattern felt by the patient. Pressing the “Vector, amplitude modulation” control during treatment will modulate the intensity of the outputs of the two channels during treatment, increasing the area covered by the interference pattern.

4. Bipolar electrode placement techniques

Bipolar electrode placement techniques should be used to provide stimulation to larger muscle groups, such as the quadriceps or the hamstrings. The symmetrical waveforms of the “Premodulated”, “Medium Frequency” and “Biphasic” waveforms are usually applied to the body using the bipolar technique.

Equal size electrodes are placed at each end of the muscle or muscle group. Current concentration is over the entire length of that muscle or muscle group and especially effective on weak musculature. Electrode placement should be at opposite ends of the limb or muscle group. Care should be taken to insure that electrodes are not placed too close together which could produce current concentration along the edges of the pads. This is the so-called “edging effect” which can cause patient discomfort. The figure on the left shows a pad set up for stimulation of the quadriceps.

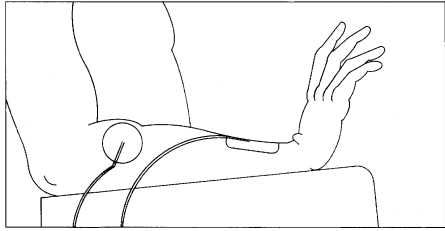

Figure 4.5 – Monopolar Electrode Placement Technique

5. Monopolar electrode application techniques

Monopolar techniques may be used with the “Premodulated”, “Medium Frequency” and “Biphasic” waveforms. The smaller, active, electrode (black and negative) is placed over the muscle motor point. In treatments designed to relieve pain, the active electrode is placed over the painful area. The larger, dispersive, electrode (red and positive) is placed on the same side of the body at some point distal to the active electrode. The dispersive pad is generally three to four times larger than the active electrode so that current density is too low to cause muscle contractions under the dispersive electrode. Never place the dispersive electrode over the antagonist muscle.

The monopolar electrode placement technique has been found to be especially useful for muscle stimulation of the upper extremities and small muscle groups. This technique helps concentrate the stimulation effect on the muscle under the smaller electrode. The figure on the left illustrates one possible electrode placement for muscle stimulation of the forearm.

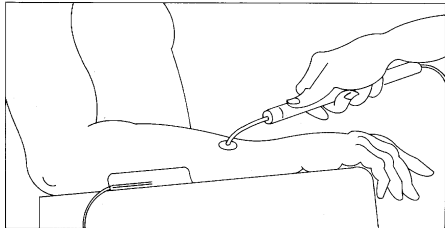

Figure 4.6 – Using the Pencil Electrode

6. Using the pencil electrode

The pencil electrode is used for the stimulation of small muscles or painful areas. It is also useful to help identify the exact motor point of a muscle or muscle group. The pencil electrode may be used with the “Premodulated”, “Medium Frequency” or “Biphasic” waveforms.

Attach the pencil electrode to the black electrode cable using a pin to banana adapter. Attach the red electrode cable to a dispersive pad. Apply dispersive electrode in such a manner to prevent transthoracic stimulation

Pressing the switch located on the pencil electrode will allow treatment currents to be delivered to the patient. Four tips of different sizes are included with the pencil electrode. The figure on the left shows an application of the pencil electrode.



7. Additional information about electrode placement:

Motor point charts are available as guides from Mettler Electronics Corp. These points may vary from patient to patient, and at time of injury, may vary in the same patient. “Functional Electrical Stimulation - A Practical Clinical Guide” by Benton, Baker, Bowman and Walters: published by Rancho Los Amigos of Downey, California is an excellent guide for electrode placement for muscle stimulation. “Clinical Transcutaneous Electrical Nerve Stimulation” by Mannheimer and Lampe is a good source for electrode placement techniques for pain management.

4.4 Combination Therapy Using the Sys*Stim 226 and the Sonicator

Application of simultaneous therapeutic ultrasound and electrical neuromuscular stimulation can be accomplished using the pulsed waveforms from the Sys*Stim 226 with a Sonicator therapeutic ultrasound unit from Mettler Electronics Corp.

In this technique, the ultrasound applicator delivers the ultrasonic energy and becomes the active electrode for muscle stimulation. **WARNING:** Apply dispersive electrode in such a manner to prevent transthoracic stimulation. Follow the instructions below to administer combination therapy.

Instructions for Combination Therapy:

Combination therapy may be performed by plugging in the black lead wire with a pin to banana adapter attached into the receptacle on the bottom of the Sonicator 705, 706, 715, 716, 710, 720, 730 or 740. The other lead wire from the same channel is attached to a treatment electrode, which is then applied to the patient to complete the electrical circuit. (Avoid transthoracic stimulation!) When electrical output is generated by the Sys*Stim 226, it will be passed through the metal ring on the Sonicator applicator.

NOTE: It is necessary to use a preparation such as Sonigel, which conducts both electric currents as well as ultrasonic energy, as a couplant for combination therapy. Non conductive materials such as mineral oil are not suitable for this application.

It is not necessary to input time on the Sys*Stim 226. The Sonicator controls all timing. Do not use the “Interferential” mode for combination therapy. Place the Sys*Stim 226 into the “Continuous” mode. When all treatment parameters have been set on both units, press “⬇” on the Sys*Stim 226. Apply the ultrasound applicator to the gelled treatment area on the patient and adjust the stimulation intensity on the Sys*Stim 226. Then press “Go” on the Sonicator and adjust ultrasound output on the Sonicator intensity control. When the selected time has elapsed on the Sonicator and the end-of-treatment buzzer sounds, press “Hold” on the Sys*Stim 226 before removing the applicator from the patient to stop electrical stimulation output.

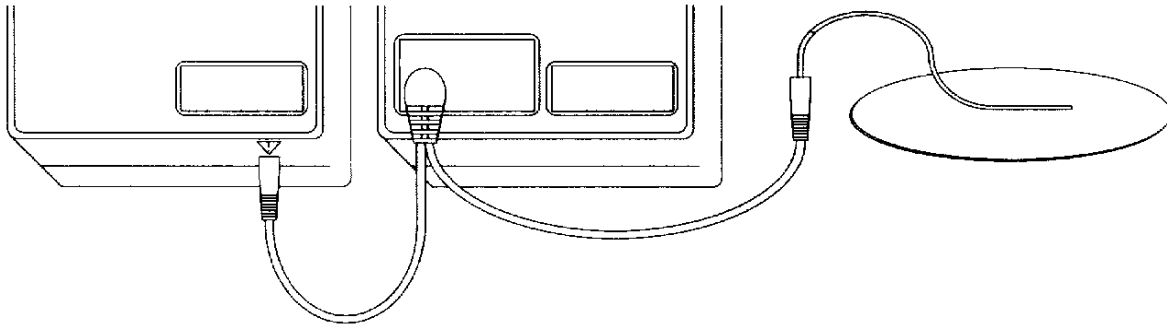

Figure 4.7 – Combination Therapy

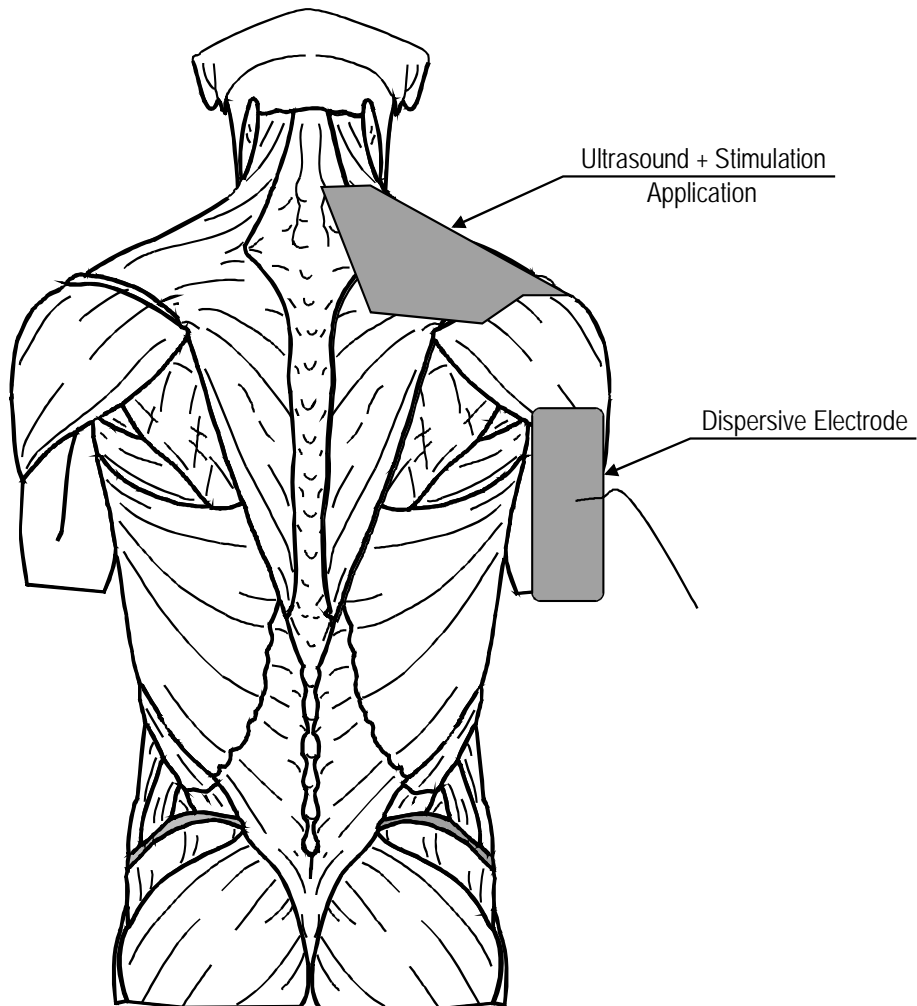

Figure 4.8 – Application of Combination Therapy

Section 5—

Indications, Contraindications, Precautions and Adverse Reactions

5.1 Indications

The application of pulsating electric currents to the body via electrodes elicits responses from nerves, which conduct pain sensation and muscle contraction information. Stimulation of sensory fibers will help block pain while the stimulation of motor fibers will generate pulsatile contractions of the muscle groups innervated by the nerves being stimulated.

Based on this information, some of the indications for use are as follow:

1. Symptomatic relief of chronic intractable pain, acute post traumatic pain or acute post surgical pain (*Interferential or Premodulated waveforms*)
2. Temporary relaxation of muscle spasm
3. Prevention of post-surgical phlebo-thrombosis through immediate stimulation of calf muscles
4. Increase of blood flow in the treatment area
5. Prevention or retardation of disuse atrophy in post-injury type conditions
6. Muscle re-education
7. Maintaining or increasing range of motion

5.2 Contraindications

1. Electrical neuromuscular stimulation should not be administered to individuals who are or may be pregnant.
2. Do not stimulate a patient who has a cardiac demand pacemaker.
3. Placement of electrodes across the chest laterally or anterior/posterior creates a possible hazard with cardiac patients and is therefore not recommended. Do not use transthoracically in any mode. Great care should be exercised in applying the electrical stimulus current to any region of the thorax because the stimulus current may produce cardiac arrhythmia. In patients with known heart disease, electrical stimulation should be used only after careful physician evaluation and patient instruction.
4. Place electrodes in such a way to avoid stimulation of the carotid sinus (neck) region.
5. Patients with arterial or venous thrombosis or thrombophlebitis are at risk of developing embolisms when electrical stimulation is applied over or adjacent to the vessels containing the thrombus. If a patient has a history of deep vein thrombosis, even many years past, the affected area should not be stimulated.
6. Do not use over swollen, infected, or inflamed areas. Do not place electrodes over skin eruptions.

7. Fresh fractures should not be stimulated in order to avoid unwanted motion.
8. Do not apply stimulation transcerebrally (through the head).
9. Do not use on cancer patients.
10. Stimulation should not be applied immediately following trauma or to tissues susceptible to hemorrhage.
11. Positioning electrodes over the neck or mouth may cause severe spasm of the laryngeal or pharyngeal muscles. These contractions may be strong enough to close the airway or cause difficulty in breathing.
12. Do not apply stimulation for undiagnosed pain syndromes, until etiology is established.
13. Do not apply electrodes directly over the eyes or inside body cavities.
14. Do not use electrical stimulation in conjunction with high frequency surgical equipment or microwave therapy systems.

5.3 Warnings

1. Electrical stimulation is ineffective for pain of central origin.
2. Electrical stimulation must be applied by a physician or other qualified practitioner and should be used for only the prescribed purposes.
3. Electrical stimulation is of no curative value.
4. Electrical stimulation is a symptomatic treatment and as such suppresses the sensation of pain, which could serve as a protective mechanism.
5. The safety of electrical stimulators for use on children has not been determined. Keep out of reach of children.
6. Electronic monitoring equipment (such as ECG monitors and ECG alarms) may not operate properly when electrical stimulation is in use.

5.4 Precautions

1. Care should be taken in the treatment of patients receiving another type of electrotherapeutic treatment (such as conventional TENS) or having indwelling electrodes, lead wires, or transmitters (for electrophrenic pacing or cerebellar or urinary bladder stimulation). Stimulation currents should not cross the lead wires or electrodes.
2. It is advisable to insulate patients, preferably by use of a wooden treatment table or one that is completely padded by non-conductive material. Added safety is provided if the patient cannot touch any grounded metal parts.
3. Limit treatment intensity to 50 mA (50 V) or less, when using small electrodes (2" X 2", pencil or smaller), to reduce the chance of thermal burns due to high current density.
4. Isolated cases of skin irritation may occur at the site of electrode placement following long-term application.

5. Avoid placing electrodes directly over open wounds since current density tends to concentrate in these areas.
6. Use extreme caution when treating desensitized areas or on patients who may not be able to report discomfort or pain.
7. Use caution in applying electrical stimulation over areas where there is a loss of normal skin sensation.
8. Adequate precautions should be taken in the case of persons with suspected or diagnosed epilepsy.
9. Patients should not be left unattended during any treatment.
10. Care should be taken following recent surgical procedures when muscle contraction may disrupt the healing process.
11. Do not apply electrical stimulation over the menstruating uterus.
12. The long-term effects of chronic electrical stimulation are unknown.
13. Effectiveness for pain management is highly dependent upon patient selection by a person qualified in the management of pain patients.

5.5 Side Effects/Adverse Reactions

1. Skin irritation and burns beneath the electrodes have been reported with the use of electrical muscle stimulators.
2. Possible allergic reactions to tape, gel or electrodes may occur.

Section 6—Maintenance and Troubleshooting

6.1 Cleaning the Sys*Stim 226

1. The Sys*Stim 226 can be wiped off with a damp cloth. The power cord should be disconnected from the unit before this is done. In the case of stubborn dirt a gentle household cleaner can be sprayed on the cloth and then wiped on the unit. If this method is used, remove any cleaner residue with a damp cloth. Do not spray cleaner into the vents of the unit.
2. Follow the EZ Trode package insert for the use and care of the electrodes supplied with the Sys*Stim 226.
3. For routine cleaning of the electrode cables use soap and water. Thoroughly dry after cleaning.

6.2 Routine Maintenance

1. Standard medical electrical safety checks should be performed annually by qualified biomedical engineers or technicians trained to perform these procedures.
2. Inspect electrode cables and associated connectors for damage.

6.3 Troubleshooting the Sys*Stim 226

Symptom	Action
1. Nothing lights when main power switch is turned on.	Is line cord connected to outlet? Does the outlet have power? Unit may require servicing if none of the above resolves the problem.
2. "E_01" displayed in Time window.	Computed checksum for EPROM microcode is in error. Unit requires servicing.
3. "E_02" displayed in Time window.	Communication error between main microprocessor and waveform generator microprocessor. If powering unit OFF and restarting does not remove error, unit requires servicing.
4. "E_03" displayed in Time window.	Output voltage error, deviation from preset or expected value. If powering unit OFF and restarting does not remove error, unit requires servicing.

5. “E_05” displayed in Time window.

Output overcurrent detected. Current exceeded 70 mA RMS for interferential, 55 mA for premodulated, and medium frequency or 105 mA peak for biphasic.

Reposition electrodes farther apart. Remove any moisture or gel from between the electrodes and try again. If error persists even without a patient connection or load, unit requires servicing.
6. “E_07” displayed in Time window.

Inadequate patient connection – patient connection impedance is increasing because the electrodes are drying out or lifting from the patient or there is an inadequate connection to the electrode cables.

In the continuous treatment modes the output voltage is reduced while the unit monitors the impedance of the patient connection. If the unit is in amplitude modulated modes, such as recip or surge, this patient connection error causes the unit to go into the HOLD mode.

All patient connection errors should be investigated to determine their cause.
7. “FF08” displayed in Time window.

If this error code is displayed when you turn on the unit, it indicates an error in the output channel test. This test includes testing of the output relays. Turn off the power to the unit and turn it back on. If the Sys*Stim 226 continues to display this error code, remove the electrode cables from the unit and turn the unit off and then back on again. If the Sys*Stim continues to display this error code, it requires service.

If the “FF08” does not display, then reattach the electrode cables and turn on the unit. If the error code reoccurs then the impedance is too low in the electrode cable circuit. Check to see if the electrodes are touching each other. If not, call for additional assistance.
8. “FF01” through “FF07” displayed in Time window.

The Sys*Stim 226 may require service. Call for additional information.

If problem is not addressed above, or if additional troubleshooting guidance is desired, call (800) 854-9305 or you may email Mettler’s Service Department at service@mettlerelectronics.com.

The distributor who sold the Sys*Stim 226 should be able to assist you with a loaner unit during warranty service.

Section 7—References

1. Baker, L.L., Bowman, B.R., and McNeal, D.R.: "Effects of Waveform on Comfort During Neuromuscular Electrical Stimulation", *Clinical Orthopedics and Related Research*, No. 233, pp. 75–85, August, 1988.
2. Belcher, J.: "Interferential Therapy", *N.Z. Journal of Physiotherapy*, 6:29-34, 1974.
3. Benton, L., et al.: *Functional Electrical Stimulation – A Practical Guide*, Rancho Los Amigos Hospital, 1981.
4. Bowman, B.R. and Baker, L.L.: "Effects of Waveform Parameters on Comfort During Transcutaneous Neuromuscular Electrical Stimulation", *Annals of Biomedical Engineering*, Vol. 13, pp. 59–74, 1985.
5. Brooks, M.E., Smith, E.M., and Currier, D.P.: "Effect of Longitudinal Versus Transverse Electrode Placement on Torque Production by the Quadriceps Femoris Muscle during Neuromuscular Electrical Stimulation", *JOSPT*, 11:11, pp. 530–534.
6. De Dominico, G.: *New Dimensions in Interferential Therapy, a Theoretical and Clinical Guide*, Reid Medical Books, Sydney, 1987.
7. De Dominico, G.: "Motor Stimulation with Interferential Currents", *Australian Journal of Physiotherapy*, 31:225-230, 1985.
8. De Dominico, G.: "Pain Relief with Interferential Therapy", *Australian Journal of Physiotherapy*, 28:14-18, 1982.
9. DeLitto, A. and Snyder-Mackler, L.: "Two Theories of Muscle Strength Augmentation Using Percutaneous Electrical Stimulation", *Physical Therapy*, (70:158–164), 1990
10. Electrotherapy Standards Committee of the Section on Clinical Electrophysiology of the American Physical Therapy Association. *Electrotherapeutic Terminology in Physical Therapy*, APTA, 1990.
11. Ganne, J. M. "Interferential Therapy", *Australian Journal of Physiotherapy*, 22:101-110, 1976.
12. Hayes, K.W.: *A Manual for Physical Agents*, Appleton & Lange, 1993.
13. Hecox, B., Mehreteab, T.A. and Weisberg, J.: *Physical Agents – A Comprehensive Text for Physical Therapists*, Appleton & Lange, 1994.
14. Kahn, J.: *Low Volt Technique*, Syosset, N.Y., 1976.
15. Kahn, J.: *Principles and Practice of Electrotherapy*, Churchill Livingstone, 1987.
16. Killian, C.B.: "Electrical Stimulation Overview, Introduction to High Frequency Stimulation", *Stimulus*, 1986.
17. Kottke, F.J., Stillwell, G.K. and Lehman, J.F., eds.: *Krusen's Handbook of Physical Medicine and Rehabilitation*, W.B. Saunders Company, 1982.
18. Low, J. and Reed, A.: *Electrotherapy Explained – Principles and practice*, Butterworth-Heinemann, 1994.

19. Lutz, G.E., Stuart, M.J. and Sim, F.H.: "Rehabilitative Techniques for Athletes after Reconstruction of the Anterior Cruciate Ligament", *Mayo Clin Proc*, (65:1322-1329, 1990.
20. Jaskoviak, P.A. and Schafer, R.C.: *Applied Physiotherapy – Practical Clinical Applications with Emphasis on the Management of Pain and Related Syndromes*, Associated Chiropractic Academic Press (A.C.A.), 1986.
21. Jorgenson, S. P. "Interferential Therapy", *ACA Journal of Chiropractic*, 23:12, 28-30, 1986.
22. Mannheimer, J.S. and Lampe, G.N: *Clinical Transcutaneous Electrical Nerve Stimulation*, F. A. Davis Company, 1984.
23. Nelson, R.M. and Currier D.P.: *Clinical Electrotherapy*, Appleton and Lange, 1991.
24. Nikolova, L.: *Treatment with Interferential Current*, Churchill Livingstone, 1987.
25. Prentice, W.E.: *Therapeutic Modalities in Sports Medicine*, Times Mirror/Mosby College Publishing, 1990.
26. Savage, B. *Interferential Therapy*, Faber and Faber, Boston, 1984.
27. Selkowitz, D.M.: "Improvement in Isometric Strength of the Quadriceps Femoris Muscle after Training with Electrical Stimulation", *Physical Therapy*, (65:186-196), 1985.
28. Snyder-Mackler, L. and Robinson, A. J., eds.: *Clinical Electrophysiology, Electrotherapy and Electrophysiologic Testing*, Williams and Wilkins, 1989.
29. Starkey, C.: *Therapeutic Modalities for Athletic Trainers*, F. A. Davis Company, 1993.
30. Wadsworth, H. and Chanmugam, A.P.P.: *Electrophysical Agents in Physiotherapy – Therapeutic and Diagnostic Use*, Science Press, Marrickville NSW 2204 Australia, 1983.
31. Wilkie, C. D. "Interferential Therapy", *Physiotherapy*, 55: 503-506, 1969.
32. Wolf, S.L., ed.: *Electrotherapy*, Churchill Livingstone, New York, 1981.

This manual has been written as a guideline for the correct use of the Sys*Stim 226. Reading the above references will provide a more complete understanding of the correct applications of neuromuscular electrical stimulation.

Section 8—Specifications

8.1 General Specifications:

Input:	115 VAC \pm 10%, 50/60 Hz, 0.4 Amp Nom.
Weight:	4.8 pounds
Dimensions:	4.3 in (H) x 6 in (D) x 13.4 in (L)
Operating Temperature:	+50°F to +131°F
Humidity:	Operating, 30% to 75% Relative Humidity at 104°F Nonoperating, up to 90% Relative Humidity at 149°F
Storage Temperature:	-40°F to 167°F
Treatment timer: Indicator:	Treatment time counts down to zero when time is set, or up to 60 minutes when no time is set. The digital timer indicates time in minutes and seconds. The timer also indicates the remaining or elapsed treatment time during the "Hold" period.
Accuracy:	\pm 5%
Maximum treatment time:	60 minutes

8.2 Waveform Specifications:

Interferential Mode

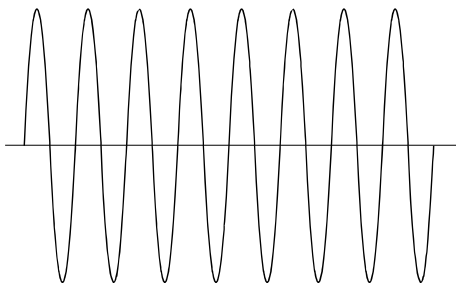

Figure 8.1 – Interferential Waveform

Waveform Type:	Sinewave
Volts:	0–65 volts RMS, 1 Kohm load
Current:	0–65 mA RMS, 1 Kohm load
Average current at maximum intensity and frequency:	65 mA RMS
Maximum current density under 2" diameter electrode.	3.2 mA/cm ²
Frequency:	Channel 1 = 4000 Hz Channel 2 = 4000 to 4250 Hz variable frequency sine wave
Frequency Modulation:	1–15 Hz 80–150 Hz 1–150 Hz xx–xx Hz, <i>xx=any value from 1 to 250 Hz</i>

Phase Duration:	125 μ s
Available Amplitude	
Modulation Options:	Vector rotation
Two Timer Option:	No

Premodulated Mode

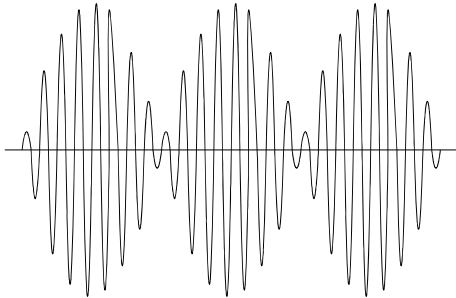

Figure 8.2 – Premodulated Waveform

Waveform Type:	Amplitude modulated sine wave
Volts:	0-50 volts RMS, 1 Kohm load
Current:	0-50 mA RMS, 1 Kohm load
Average current at maximum intensity and frequency:	50 mA RMS
Maximum current density under 2" diameter electrode.	2.5 mA/cm ²
Frequency:	4,000 Hz
Frequency Modulation:	1-15 Hz 80-150 Hz 1-150 Hz xx-xx Hz, <i>xx=any value from 1 to 250 Hz</i>
Phase Duration:	125 μ s internal sine wave 4-1,000 ms beat envelope
Available Amplitude	
Modulation Options:	Continuous Surge Reciprocation
Two Timer Option:	Yes

Medium Frequency Mode

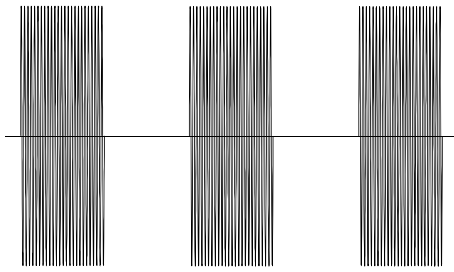

Figure 8.3 – Medium Frequency (Russian) Waveform

Waveform Type:	Burst modulated sine wave
Volts:	0–50 volts RMS, 1 Kohm load
Current:	0–50 mA RMS, 1 Kohm load
Average current at maximum intensity and frequency:	50 mA RMS
Maximum current density under 2" diameter electrode.	2.5 mA/cm ²
Frequency:	2500 Hz, Burst at 10 ms on and 10 ms off
Frequency Modulation:	No
Phase Duration:	200 μs
Available Amplitude Modulation Options:	Continuous Surge Reciprocation
Two Timer Option:	Yes

Biphasic Mode

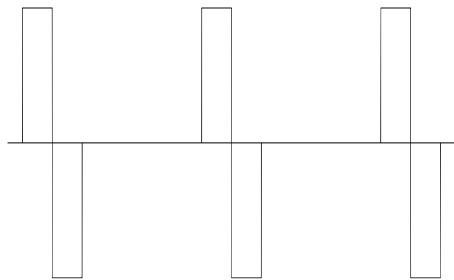

Figure 8.4 – Biphasic Waveform

Waveform Type:	Symmetrical biphasic square wave
Volts:	99 volts peak, 1 Kohm load
Current:	0 –99 mA peak, 1 Kohm load
Average current at maximum intensity and frequency:	7.2 mA
Maximum current density under 2" diameter electrode.	0.36 mA/cm ²
Frequency:	1–120 Hz
Frequency Modulation:	No
Phase Duration:	50–300 μs
Available Amplitude Modulation Options:	Continuous Surge Reciprocation
Two Timer Option:	Yes

8.3 Amplitude Modulation Specifications:

Vector rotation:	<i>Interferential Mode Only,</i>
	±50% amplitude modulation in anti phase with an eight second modulation period.
Two timer option	No
Surge Mode:	<i>Premodulated, Medium Frequency and Biphasic Pulsed Modes</i>
Up ramp:	3 seconds
Down ramp:	2 seconds
Preset on/off times:	10 seconds on, 10 seconds off 10 seconds on, 20 seconds off 10 seconds on, 30 seconds off 10 seconds on, 40 seconds off 10 seconds on, 50 seconds off 10 seconds on, 60 seconds off
Programmable On time:	1-240 seconds
Programmable Off time:	1-240 seconds
Two timer option:	Yes
Reciprocation mode:	<i>Premodulated, Medium Frequency and Biphasic Pulsed Modes</i>
Up and down ramps:	1 second, <i>reciprocation only</i>
Reciprocation time:	2-240 seconds, (On time = off time)
Combine with Surge:	Use up and down ramps of surge program Use on/off times of surge program.
Two timer option:	No

Section 9—Accessories

9.1 Ordering Information:

Therapy products and accessories are available from Mettler Electronics authorized Distributors. For information regarding either Mettler products or a distributor near you, please call toll free, (800) 854-9305 or phone (714) 533-2221 in areas outside the continental United States. Ask for Customer Service. Mettler Electronics is open from 7 AM until 5 PM Pacific Time for your convenience.

9.2 Sys*Stim 226 Accessories

Catalogue #	Item Description
107	Travel bag – Ideal for carrying the Sys*Stim to the patient. Holds one Sys*Stim 226 and its accessories
1004	Sonicator mounting plate, complete with three wood screws (Fits all Sonicator and Sys*Stim units)
1844	Sonigel – salt free colloidal water couplant, case of 12, 9.5 oz. tubes
1851	Sonigel clear gel couplant, (12 x 250 ml bottles)
1852	Sonigel clear gel couplant, (1 x 5 liters)
1853	Sonigel clear gel couplant, (4 X 5 liters)
1860	Sonigel – salt free colloidal water couplant, case of 4 boxes of 1844
1861	Sonigel – salt free colloidal water couplant, case of 4 boxes of 1851
1863	Sonigel Lotion with Aloe Vera (1 X 1 G), pump included with each gallon container
1864	Sonigel Lotion with Aloe Vera (4 cases x 1863)
2000	4 Sponge electrodes (2" x 2")
2001	24 Sponge inserts (2" x 2")
2002	4 Sponge electrodes (4" x 4")
2003	24 Sponge inserts (4" x 4")
2004	1 Sponge electrode (3.5" x 7")
2005	12 Sponge inserts (3.5" x 7")
2006	1 Sponge electrode (8" x 10")
2007	12 Sponge inserts (8" x 10")
2008	4 Electrode straps (24")
2009	4 Electrode straps (48")
2023	Pencil electrode set with push button stimulation control, (includes handle, 4 different sizes of stainless steel spot electrode tips, and carrying case)

2027	Pin to banana adapter plug set to be used with ME 2026, 2260 or 2201 electrode cables. Four each, gray.
2030	Bifurcation cable set, 2 cables, one red and one black, pin termination
2260	Electrode cable for the Sys*Stim 226 with pins
2221	EZ Trode – 2" diameter round self-adhering, reusable electrodes with lead wires; case of ten packages (four electrodes/pkg.)
2222	EZ Trode – 2.75" diameter round self-adhering, reusable electrodes with lead wires; case of ten packages (four electrodes/pkg.)
2223	EZ Trode – 2" x 5" self-adhering, reusable electrodes with lead wires, case of 10 packages (2 electrodes/pkg.)
2224	EZ Trode – 2" square self-adhering, reusable electrodes with lead wires; case of ten packages (four electrodes/pkg.)
2702	V Trode –2" diameter round electrodes with lead wires, case of ten packages (four electrodes/pkg.)
2703	V Trode –2.75" diameter round electrodes with lead wires, case of 10 packages (four electrodes/pkg.)
2704	V Trode –2" x 4" oval electrodes with lead wires, case of 10 packages (four electrodes/pkg.)
2705	V Trode –2" square electrodes with lead wires, case of 10 packages (four electrodes/pkg.)
73	Mobile cart – Can hold any Sonicator therapeutic ultrasound with the Sys*Stim 226, side by side. Has two additional shelves to hold supplies.
74	Rugged plastic cart features three shelves and large lockable wheels.
75	Model 74 cart with a built-in hospital-grade surge protector to plug-in up to three pieces of equipment.
7293	Detachable U.L. listed, hospital-grade line cord